



*Installation, Operation, and
Maintenance Manual*

Welker® Automatic Insertion Probe

*Model
AID-3*

The information in this manual has been carefully checked for accuracy and is intended to be used as a guide for the installation, operation, and maintenance of the Welker equipment described above. Correct operating and/or installation techniques, however, are the responsibility of the end user. Welker reserves the right to make changes to this and all products in order to improve performance and reliability.

13839 West Bellfort
Sugar Land, TX 77498-1671
(281) 491-2331 - Office
(800) 776-7267 - USA Only
(281) 491-8344 - Fax
<http://www.welkereng.com>

This page intentionally left blank

TABLE OF CONTENTS

1	GENERAL	4
1.1	Introduction.....	4
1.2	Product description	4
1.3	Specifications.....	5
2	INSTALLATION INSTRUCTIONS	7
2.1	General.....	7
2.2	Preparing for installation.....	7
2.3	Determining the required insertion pressure	8
2.4	Inserting the shaft.....	8
2.5	Removing the cylinder assembly	9
2.6	Retracting the probe.....	9
2.7	Helpful Hints.....	10
3	MAINTENANCE INSTRUCTIONS	11
3.1	General.....	11
3.2	Maintenance instructions	12
3.3	Reassembly	12

Welker®, Welker Jet®, and WelkerScope® are Registered Trademarks owned by Welker Engineering Company.

INTRODUCTION

1 GENERAL

1.1 Introduction

We appreciate your business and your choice of Welker Engineering Company products. The installation, operation, and maintenance liability for this product becomes that of the purchaser at the time of receipt. Reading the applicable *Installation, Operation, and Maintenance (IOM) Manual* prior to installation and operation of this equipment is required for a full understanding of its application and performance prior to use. If you have any questions, please call 1-800-776-7267 in the USA or (1) 281-491-2331.

The following procedures have been written for use with standard Welker Engineering parts and equipment. Assemblies which have been modified may have additional requirements and specifications that are not listed in this manual.

Notes, Warnings, and Cautions



NOTE

Notes emphasize information or set it off from the surrounding text.



CAUTION

Caution messages appear before procedures that, if not observed, could result in damage to equipment.



WARNING

Warnings alert users to a specific procedure or practice that, if not followed correctly, could cause personal injury.

1.2 Product description

The Welker® Automatic Insertion Sample Probe is designed for use in systems where it is desirable to insert and retract a probe within a pipeline while the pipeline remains pressurized. The device incorporates a cylinder and piston assembly to help provide a safe and smooth insertion of the probe. When inserting the shaft, the cylinder assembly must be first installed on the unit. Pipeline pressure is then applied to the cylinder's piston, allowing the probe shaft to automatically insert into the pipeline. Once the shaft is inserted and locked into the pipeline, the cylinder assembly is then removed and the customer can install the required equipment to the end of the probe shaft.

SPECIFICATIONS

1.3 Specifications

N NOTE

The specifications listed in this section are generalized for this equipment. Welker Engineering Company can modify the equipment according to your company's needs. However, please note that **the specifications may vary depending on the customization of your product.**

Table 1

General	
Products	Natural gas and other gases and liquids compatible with the materials of construction.
Materials of Construction	Stainless Steel, Carbon Steel, PTFE, and Viton (others available)
Probe Maximum Allowable Operating Pressure	1440 psi @ -20° F to 100° F (102 bar @ -29° C to 37° C)
Insertion Housing Maximum Allowable Operating Pressure	130 psi @ -20° F to 100° F (9 bar @ -29° C to 37° C)
Insertion Length	0" to 120" (0mm to 3048mm)
Viscosity Range	0.009cp to 2000cp @ 68° F
Pipeline Connection	NPT or Flanged
Sample Outlet Connection	1/4" FNPT

SPECIFICATIONS

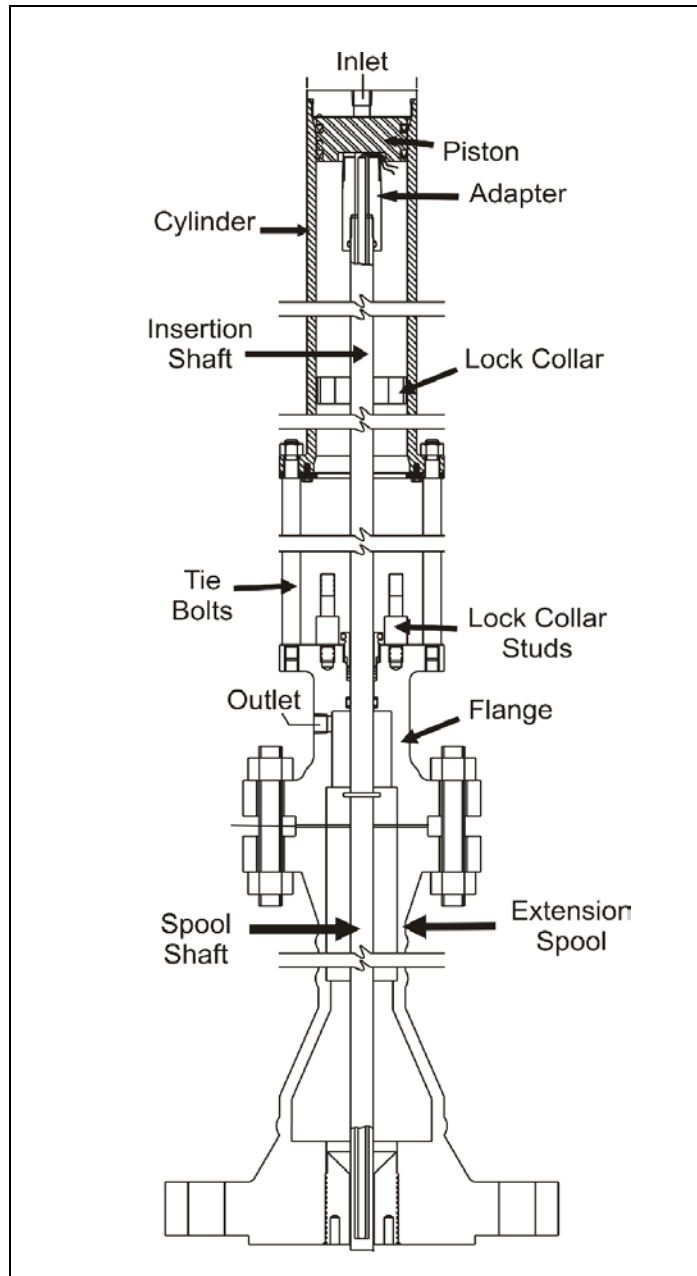

Figure 1

INSTALLATION & OPERATION

2 INSTALLATION INSTRUCTIONS

2.1 General

After unpacking the unit, check it for compliance and for any damages which may have occurred during shipment.

N NOTE

Claims for damages caused during shipment must be initiated by the receiver and directed to the shipping carrier. Welker Engineering Company is not responsible for damages caused from mishandling by the shipping company.

N NOTE

When sealing fittings with PTFE tape, refer to the proper sealing instructions for the tape used.

2.2 Preparing for installation

2.2.1 Connect the extension spool to the pipeline isolation valve.

2.2.2 Connect the flange to the extension spool, inserting the insertion shaft into the lower spool shaft (see Figure 1).

2.2.3 Bolt the flange to the extension spool.

2.2.4 **Determining the shaft insertion length:**

- Begin at the top of the pipeline isolation valve and measure down to the center $\frac{1}{3}$ of the pipeline.
- Pull up on the insertion shaft to make sure it's fully retracted.
- Measure the insertion length (determined in step a) on the shaft itself. Begin at the top of the flange and measure up on the shaft.
- Mark this point on the shaft, as this is where the lock collar will be positioned.
- Move the lock collar to the marked point and tighten the set screws in the collar to hold it in place.

2.2.5 Position the tie bolts on the flange (see Figure 1).

2.2.6 Make sure the cylinder's piston is pushed to the bottom of the cylinder (see Figure 2).

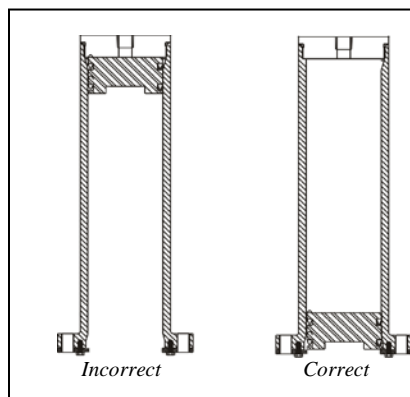

Figure 2

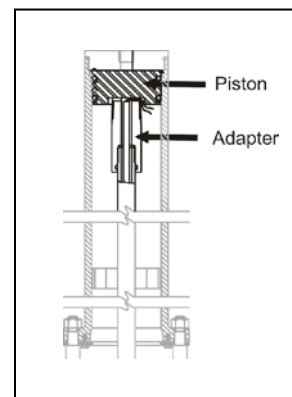

Figure 3

2.2.7 Position the cylinder on top of the tie bolts. The piston should fit over the adapter (see Figure 3).

2.2.8 Tighten the six tie bolt hex nuts to connect the cylinder to the tie bolts.

INSTALLATION & OPERATION

2.3 Determining the required insertion pressure

Use the following formula to determine the exact pressure required to insert the probe.

$$3.14 \left(\frac{\text{probe diameter}}{2} \right)^2 \left(\text{pipeline pressure} \right) = \text{force on end of probe shaft}$$

$$\left(\frac{\text{force on end of probe shaft}}{3.14 (\text{piston diameter}/2)^2} \right) = \text{instrument supply pressure for insertion housing}$$

2.4 Inserting the shaft

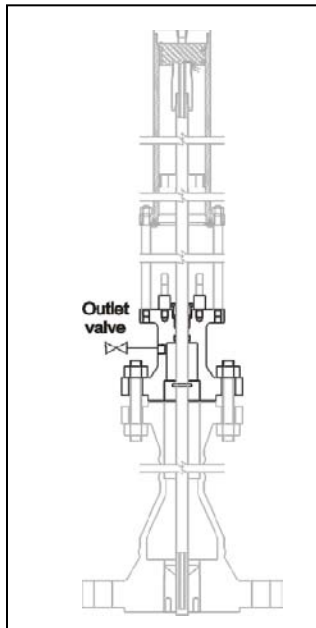

Figure 4

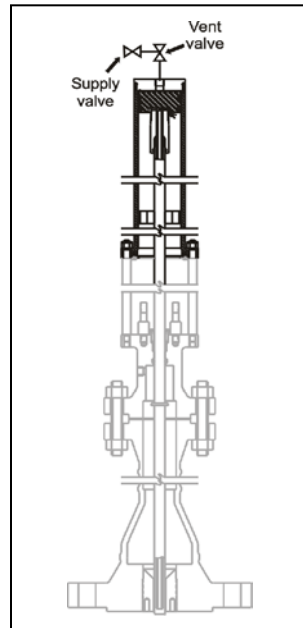

Figure 5

- 2.4.1 Install a valve in the outlet port of the flange (see Figure 4). Make sure the valve is closed.
- 2.4.2 Use tubing to connect an instrument regulator, relief, and gauge to the outlet valve. Set the instrument regulator to the pressure determined in section 2.3.
- 2.4.3 Connect a vent valve and a supply valve to the inlet port of the cylinder (see Figure 5). Make sure both valves are closed.

INSTALLATION & OPERATION

- 2.4.5 Connect the cylinder valve assembly to the flange valve assembly (see Figure 6).
- 2.4.6 Open the pipeline isolation valve.
- 2.4.7 Open the outlet valve on the flange.
- 2.4.8 **Slowly** open the supply valve on the cylinder. Pipeline pressure will begin to push against the piston, causing the shaft to insert.
- 2.4.9 When the shaft's lock collar protrudes from the cylinder, carefully guide it over the lock collar studs (see Figure 6) and tighten the lock collar bolts on the studs in order to hold the lock collar in place. The insertion shaft is now inserted into the pipeline at the appropriate length.

W WARNING

Keep all body parts away from the bottom of the lock collar. Guide the lock collar from the sides only.

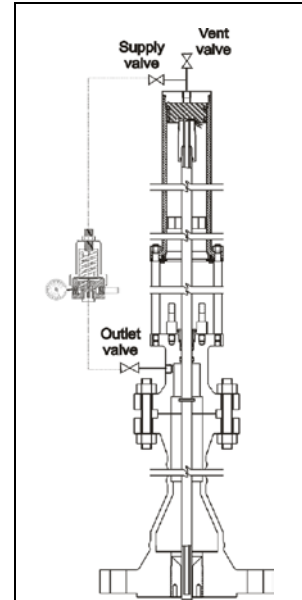

Figure 6

2.5 Removing the cylinder assembly

- 2.5.1 Close the outlet valve on the flange.
- 2.5.2 Close the supply valve on the cylinder.
- 2.5.3 **Slowly** open the vent valve on the cylinder to relieve excess pressure on the piston.
- 2.5.4 Disconnect the tubing from the cylinder to the flange.
- 2.5.5 Remove the six tie bolt hex nuts from the cylinder.
- 2.5.6 Remove the cylinder and tie bolts from the flange.
- 2.5.7 Connect the required equipment to the adapter.
- 2.5.8 The unit is now in operation.

2.6 Retracting the probe

- 2.6.1 Shut down and remove any instrumentation connected to the shaft's adapter.
- 2.6.2 Make sure the cylinder's piston is pushed to the bottom of the cylinder (see Figure 2).
- 2.6.3 Position the tie bolts on the flange.
- 2.6.4 Position the cylinder on top of the tie bolts. The piston should fit over the adapter.
- 2.6.5 Tighten the six tie bolt hex nuts to connect the cylinder to the tie bolts.
- 2.6.6 Complete steps 2.4.1 through 2.4.8 to pressurize the piston.
- 2.6.7 Once the piston has reached the end of the cylinder, **carefully** loosen the lock collar bolts from the lock collar studs.
- 2.6.8 Close the supply valve on the cylinder.
- 2.6.9 Close the outlet valve on the flange.
- 2.6.10 **Slowly** open the cylinder vent valve to vent pressure inside the cylinder. The shaft will begin to retract.

INSTALLATION & OPERATION

- 2.6.11 When the shaft is fully retracted, close the pipeline isolation valve.
- 2.6.12 Open the supply valve to depressurize the tubing connection and instrument regulator.
- 2.6.13 Complete steps 2.5.1 through 2.5.6 to remove the cylinder and tie bolts from the device.
- 2.6.14 Disconnect the device from the pipeline isolation valve.

2.7 Helpful Hints

- 2.7.1 Avoid rough handling of the unit and bending of the shaft. The shaft has a polished surface that travels through seals.
- 2.7.2 Operate the unit slowly and smoothly while inserting and retracting to avoid unnecessary slamming of the lock collar and/or the piston located inside the unit.
- 2.7.3 The most common cause for repairs to an automatic insertion device is due to the pipeline isolation valve closing on the shaft while the shaft is still inserted into the pipeline. Please avoid this practice.
- 2.7.4 The entire unit should be treated with care.

CAUTION

When applying pressure, do not exceed the maximum working pressure of the upper insertion housing (see Table 1).

NOTE

At any time pressure begins to exhaust past the packing adjustment nut, retract the probe, close the pipeline isolation valve, and replace the packing and o-ring seal prior to maintenance instructions.

MAINTENANCE

3 MAINTENANCE INSTRUCTIONS

3.1 General

Prior to maintenance or disassembly of the unit, it is advisable to have a repair kit handy for the system in case of encountering unexpected wear or faulty seals. All maintenance and cleaning of the unit should be done on a smooth, clean surface.

N NOTE

We recommend that the unit have annual maintenance under normal operating conditions. In the case of severe service, dirty conditions, excessive cycling usage, or other unique applications that may subject the equipment to unpredictable circumstances, a more frequent maintenance schedule may be appropriate.

N NOTE

New seals supplied in spare Parts kits are not lubricated. They should be lightly coated with lubrication grease (Dow Corning 111 [DC 111] or equivalent lubricant) before they are installed into the equipment. This helps with the installation of the seals while reducing the risk of damage when positioning them on the parts.

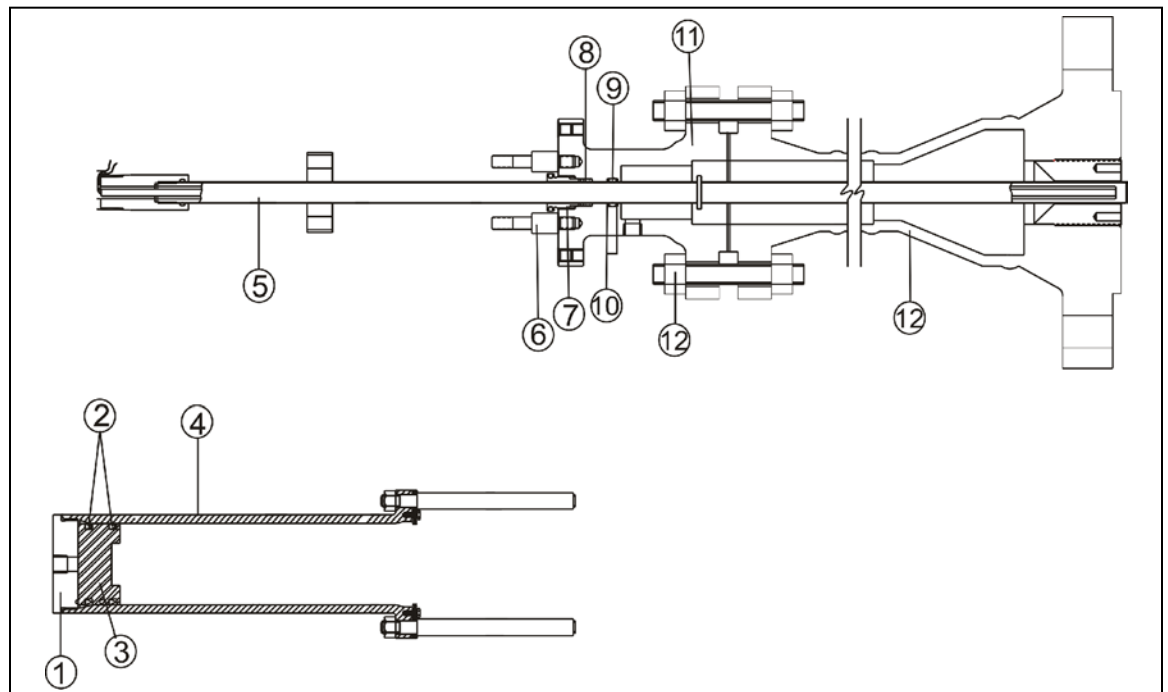

Figure 7

Refer to this figure throughout the entire maintenance process.

MAINTENANCE

3.2 Maintenance instructions

- 3.2.1 Remove the cylinder end cap (Part 1).
- 3.2.2 Use a padded wooden rod to push the piston (Part 3) out of the cylinder (Part 4).
- 3.2.3 Replace the u-cups (Part 2) in the piston.
- 3.2.4 Wipe down the inside of the cylinder and dry carefully.
- 3.2.5 Closely examine the honed surface of the cylinder. Scratches and pits will cause the seals to leak.
- 3.2.6 Remove the lock collar studs (Part 6) from the flange (Part 11).
- 3.2.7 Loosen and remove the adjustment nut (Part 7).
- 3.2.8 Remove the sixteen hex nuts (Part 12) from the flange.
- 3.2.9 Remove the flange from the extension spool.
- 3.2.10 Remove the lock collar from the shaft.
- 3.2.11 Remove the adapter from the top of the shaft.
- 3.2.12 Carefully pull the shaft out of the flange and extension spool (Part 13).
- 3.2.13 Replace the backups (Part 10) and seal (Part 9) in the flange.
- 3.2.14 Replace the v-packing (Part 8) in the flange.

3.3 Reassembly

- 3.3.1 Reinsert the shaft (Part 5) through the extension spool (Part 13)..
- 3.3.2 Reconnect the extension spool to the flange.
- 3.3.3 Reinstall the sixteen hex nuts (Part 12) to the flange.
- 3.3.4 Replace the adjustment nut (Part 7) in the flange.
- 3.3.5 Replace the lock collar studs (Part 6).
- 3.3.6 Reconnect the lock collar to the position marked in step 2.2.4.
- 3.3.7 Reconnect the adapter to the top of the shaft.
- 3.3.8 Reassemble the piston (Part 3) inside the cylinder.
- 3.3.9 Replace the cylinder end cap (Part 1).
- 3.3.10 Maintenance is now complete.

This page intentionally left blank



P.O. Box 138 Sugar Land, Texas 77487-0138

Phone: (281) 491-2331

Fax: (281) 491-8344

Toll Free: (800) 776-7267

Web Page: www.welkereng.com