



**Installation,  
Operation,  
and  
Maintenance  
Manual**

# **Welker<sup>®</sup> Liquid Sample Pump**

*Model  
LSSM-1  
LSSM-1APF*

The information in this manual has been carefully checked for accuracy and is intended to be used as a guide for the installation, operation, and maintenance of the Welker equipment described above. Correct operating and/or installation techniques, however, are the responsibility of the end user. Welker reserves the right to make changes to this and all products in order to improve performance and reliability.

13839 West Bellfort  
Sugar Land, Texas 77498-1671  
U.S.A.  
Tel.: (800) 776-7267  
Tel.: (281) 491-2331  
Fax: (281) 491-8344  
[www.welkereng.com](http://www.welkereng.com)

*This page intentionally left blank*

# TABLE OF CONTENTS

---

<b>1</b>	<b>GENERAL</b>	<b>4</b>
1.1	Introduction.....	4
1.2	Specifications.....	5
<b>2</b>	<b>INSTALLATION INSTRUCTIONS</b>	<b>6</b>
2.1	General.....	6
2.2	Installation instructions.....	6
2.3	Setting the relief for constant pressure cylinders.....	8
2.4	Setting the relief for standard cylinders.....	9
2.5	Operation instructions.....	9
<b>3</b>	<b>MAINTENANCE INSTRUCTIONS</b>	<b>10</b>
3.1	General.....	10
3.2	Instructions.....	11
3.3	Collection head maintenance.....	12
3.4	Relief maintenance.....	13
3.5	Reassembly.....	15

Welker®, Welker Jet®, and WelkerScope® are Registered Trademarks owned by Welker.

# INTRODUCTION

## 1. GENERAL

### 1.1 Introduction

We appreciate your business and your choice of Welker products. The installation, operation, and maintenance liability for this product becomes that of the purchaser at the time of receipt. Reading the applicable *Installation, Operation, and Maintenance (IOM) Manual* prior to installation and operation of this equipment is required for a full understanding of its application and performance prior to use. If you have any questions, please call 1-800-776-7267 in the USA or 1-281-491-2331.

The following procedures have been written for use with standard Welker parts and equipment. Assemblies that have been modified may have additional requirements and specifications that are not listed in this manual.

#### Notes, Warnings, and Cautions



#### NOTE

Notes emphasize information or set it off from the surrounding text.



#### CAUTION

Caution messages appear before procedures that, if not observed, could result in damage to equipment.



#### WARNING

Warnings alert users to a specific procedure or practice that, if not followed correctly, could cause personal injury.

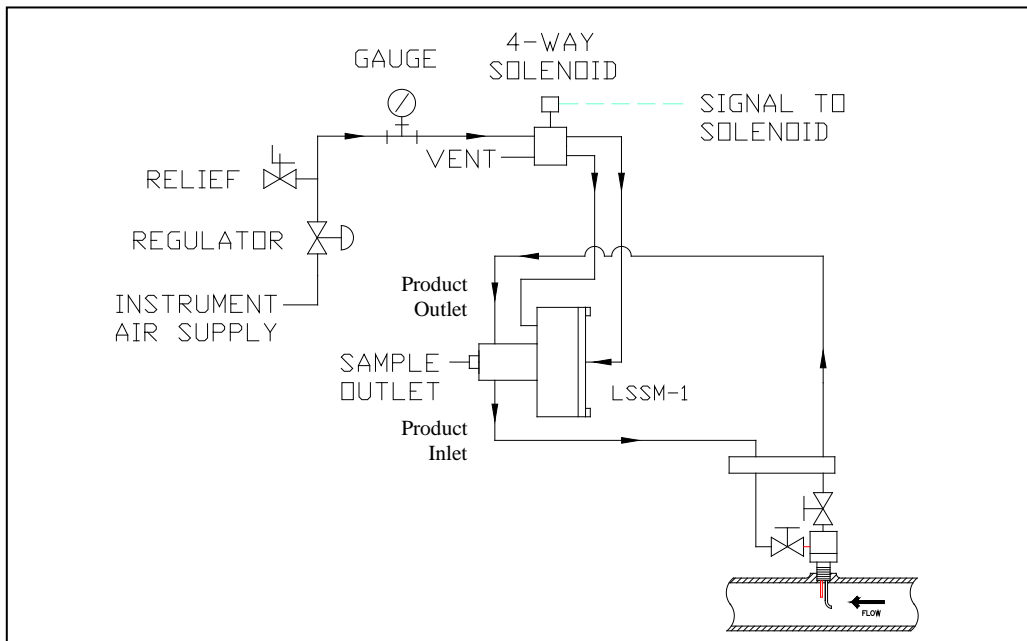

FIGURE 1

# SPECIFICATIONS

---

## 1.2 Specifications

**N** NOTE

The specifications listed in this section are generalized for this equipment. Welker can modify the equipment according to your company's needs. However, please note that **the specifications may vary depending on the customization of your product.**

**Table 1**

<b>LSSM-1 Specifications</b>	
Products	Fluids compatible with the materials of construction
Materials of Construction	316 Stainless Steel, Viton <sup>®</sup> and PTFE (others available)
Viscosity Range	8-50° API Gravity
Sample Grab Sizes (normally)	.22cc, .5cc, 1.0cc, & 1.5cc (Collection Cup) .22cc-4.0cc (B-Style Collection Head)
Grab Rate	Up to 15 grabs per minute
Temperature Range	-20° F to 400° F (-29° C to 204° C)
Maximum Line Pressure	3600 PSI (345 bar)
Sample Outlet Connection	¼" FNPT standard
Area Classification	Can be used in hazardous areas
Sample Inlet	¼", ½", ¾", 1" NPT ½"-1"-1500 Flanged

**Table 2**

<b>Utilities Required</b>	
Air/Hydraulic Pressure	40 PSI – 120 PSI (2.8 bar – 8.3 bar) Regulate to needs.
Air Consumption	0.1 SCF/Stroke (0.003 m <sup>3</sup> /Stroke)
Timing	Minimum ON time: 2 seconds Minimum OFF time: 2 seconds

# INSTALLATION

---

## 2. INSTALLATION INSTRUCTIONS

### 2.1 General

- 2.1.1 After unpacking the unit, check it for compliance and for any damages that may have occurred during shipment.

**N** NOTE

Claims for damages caused during shipping must be initiated by the receiver and directed to the shipping carrier. Welker is not responsible for any damages caused from mishandling by the shipping company.

**N** NOTE

When sealing fittings with PTFE tape, refer to the proper sealing instructions for the tape used.

- 2.1.2 The installation instructions are written from the position that the sampler is part of a complete sampler system. If it is purchased as a sampler alone, the system should be constructed in a fashion compatible with the following instructions.
- 2.1.3 A sample probe is recommended to extract the sample from the center one-third of the pipeline.
- 2.1.4 The sample probe should be located in the least turbulent area available of the flowing stream, i.e., **not in a header or blow-down stack and away from obstructions, elbows or partially closed valves.**

**N** NOTE

Typically, the Welker Sampler is installed with a pitot probe or with 2 single probes. If 2 single probes are used, one should be located upstream and the other one downstream of a moderate pressure drop such as an orifice plate or control valve. This will create a hot loop for the sampler that will allow a “real-time” sample to be taken with each new actuation.

### 2.2 Installation instructions

- 2.2.1 Connect the probe outlet to the product inlet of the sampler with ¼” stainless steel tubing.
- 2.2.2 The product outlet of the sampler (located 180° from the product inlet) should be returned to the pitot probe or a low pressure point in the pipeline with ¼” stainless steel tubing.
- 2.2.3 The sample outlet should be connected to the appropriate sample receiver with ⅛” stainless steel tubing maximum and an isolation valve if a transportable sample receiver is used.

**N** NOTE

The sample receiver should be located as close to the sampler as possible. The tubing should be sloped downward from the sampler to the sample receiver, which eliminates traps and ensures the heavier components are pumped into the receiver.

- 2.2.4 The type of sample head used will determine how the instrument supply lines are to be connected. Follow the instructions for supply setup with the appropriate collection head.

# INSTALLATION

## Vanishing Chamber Collection Head

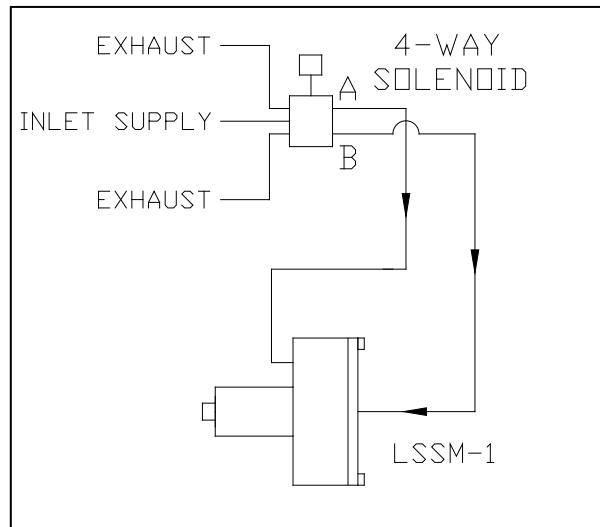

**FIGURE 2**

- 2.2.5 Connect the normally open port (stamped A or NO on most solenoids) of the 4-way solenoid to the bottom of the double acting piston motor with  $\frac{3}{8}$ " stainless steel tubing.
- 2.2.6 Connect the normally closed port (stamped B or NC on most solenoids) of the 4-way solenoid to the top of the double acting piston motor with  $\frac{3}{8}$ " stainless steel tubing (see Figure 2).

## Piston Style Collection Head

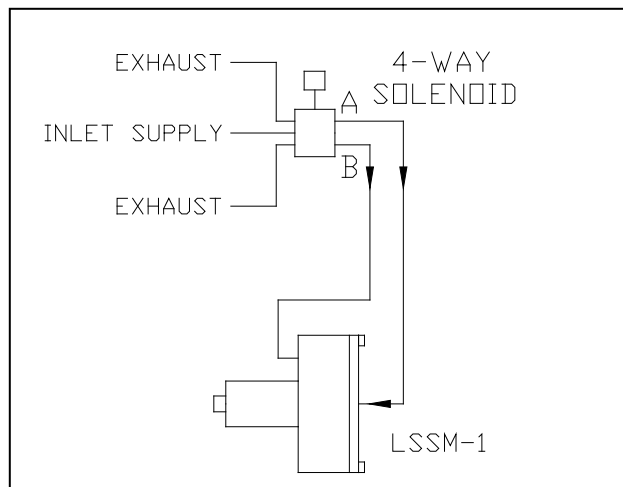

**FIGURE 3**

# INSTALLATION

---

- 2.2.7 Connect the normally closed port (stamped B or NC on most solenoids) of the 4-way solenoid to the bottom of the double-acting piston motor with 1/4" or 3/8" stainless steel tubing.
- 2.2.8 Connect the normally open port (stamped A or NO on most solenoids) of the 4-way solenoid to the top of the double-acting piston motor with 1/4" or 3/8" stainless steel tubing (see Figure 3).
- 2.2.9 Connect the regulated instrument air source to the solenoid valve.
- 2.2.10 The installation process is now complete. Refer to operating instructions to put the unit into service.

## 2.3 Setting the relief for constant pressure cylinders

- 2.3.1 Make sure that all valves on the system are closed.
- 2.3.2 If the sampler has an inline relief assembly, continue with step 2.3.3. If the sampler does not have a relief assembly, skip to Section 2.5.

### **N** NOTE

The inline relief is set at the factory per purchase order specifications (if supplied). It is labeled on a sticker on the front face of the pump.

- 2.3.3 Determine maximum pipeline pressure (i.e., 150 psi, 750 psi, etc.).
- 2.3.4 Remove the tubing fitting from the sampler relief cap.
- 2.3.5 Remove the tubing fitting on the product outlet and plug that port.
- 2.3.6 With a hex wrench, reach inside the relief cap to the spring adjustment screw.
- 2.3.7 Open the pipeline isolation valve slowly to allow pipeline pressure into the sampler body.
- 2.3.8 If the pipeline pressure is 200 psi or lower, adjust the spring setting to stop the product from bleeding past the poppet. Then, depressurize the system and replace both of the tubing fittings and tubing.
- 2.3.9 If the pipeline pressure is above 200 psi:
  - a) Adjust the spring setting to allow all but approximately 200 psi to flow past the poppet (i.e., tighten the adjustment screw to shut-off the flow, then back off approximately two full turns).
- 2.3.10 Close the pipeline isolation valve.
- 2.3.11 Put a gauge into the relief cap port.
- 2.3.12 Open the pipeline isolation valve, and read the gauge. If pipeline pressure is 750 psi, the gauge should read approximately 550 psi.
- 2.3.13 If it reads 650 psi, go back to Step 2.3.9 and add more tension by turning the wrench one full turn clockwise. If the gauge reads 450 psi, go back to step 2.3.9 and relieve tension by turning the wrench one full turn counter-clockwise. This may have to be repeated to reach an approximate relief setting of 200 psi.

### **N** NOTE

One full turn of the hex wrench equals approximately 100 psi.

- 2.3.14 Close the pipeline isolation valve.
- 2.3.15 Remove the plug in the product outlet port and replace both tubing fittings into the proper ports.

# INSTALLATION

---

## 2.4 Setting the relief for standard cylinders

- 2.4.1 Remove the tubing fitting from the sampler relief cap.
- 2.4.2 Remove the tubing fitting on the product outlet and plug that port.
- 2.4.3 With a hex wrench, reach inside the relief cap to the spring adjustment screw.
- 2.4.4 Open the pipeline isolation valve slowly to allow pipeline pressure into the sampler body.
- 2.4.5 Adjust the spring setting to stop the product from bleeding past the poppet.
- 2.4.6 Turn the wrench one more complete rotation clockwise. This sets the relief approximately 100 psi higher than pipeline pressure.
- 2.4.7 Depressurize the system, and replace the tubing and tube fittings.

## 2.5 Operation instructions

- 2.5.1 Slowly open the high pressure-valve, P1, on the pitot probe or pipeline isolation valve.
- 2.5.2 Open the low-pressure valve, P2, on the pitot probe or the other pipeline isolation valve.
- 2.5.3 Check for leaks.
- 2.5.4 If using a constant pressure cylinder, make sure that the sample receiver has the correct pre-charge pressure.
- 2.5.5 Open the sample outlet valve, if applicable, and the product inlet valve on the sample receiver.

### **N** NOTE

On constant pressure cylinders, pipeline pressure less than 200 psi should be indicated on the product side gauge of the sample receiver.

- 2.5.6 Check for leaks.
- 2.5.7 Open the proper valve(s) to allow instrument air to be applied to the sampler via the solenoid at 40 psi (this may have to be adjusted higher, depending on pipeline pressure and style of collection head).
- 2.5.8 Actuate the sampler for 10-15 strokes, and check for leaks.

### **N** NOTE

For constant pressure cylinders, the piston indicator on the sample receiver should move, indicating that a sample has been pumped into the cylinder.

- 2.5.9 Purge the cylinder according to the instructions found in the appropriate manual for the cylinder.
- 2.5.10 Set the controller to the sample frequency desired.
- 2.5.11 The sampler is now in operation.

# MAINTENANCE

## 3. MAINTENANCE INSTRUCTIONS

### 3.1 General

Prior to maintenance or disassembly of the unit, it is advisable to have a repair kit handy for the system in case of encountering unexpected wear or faulty seals. All maintenance and cleaning of the unit should be done on a smooth, clean surface.

**N** NOTE

We recommend that the unit have biannual maintenance under normal operating conditions. In the case of severe service, dirty conditions, excessive cycling usage, or other unique applications that may subject the equipment to unpredictable circumstances, a more frequent maintenance schedule may be appropriate.

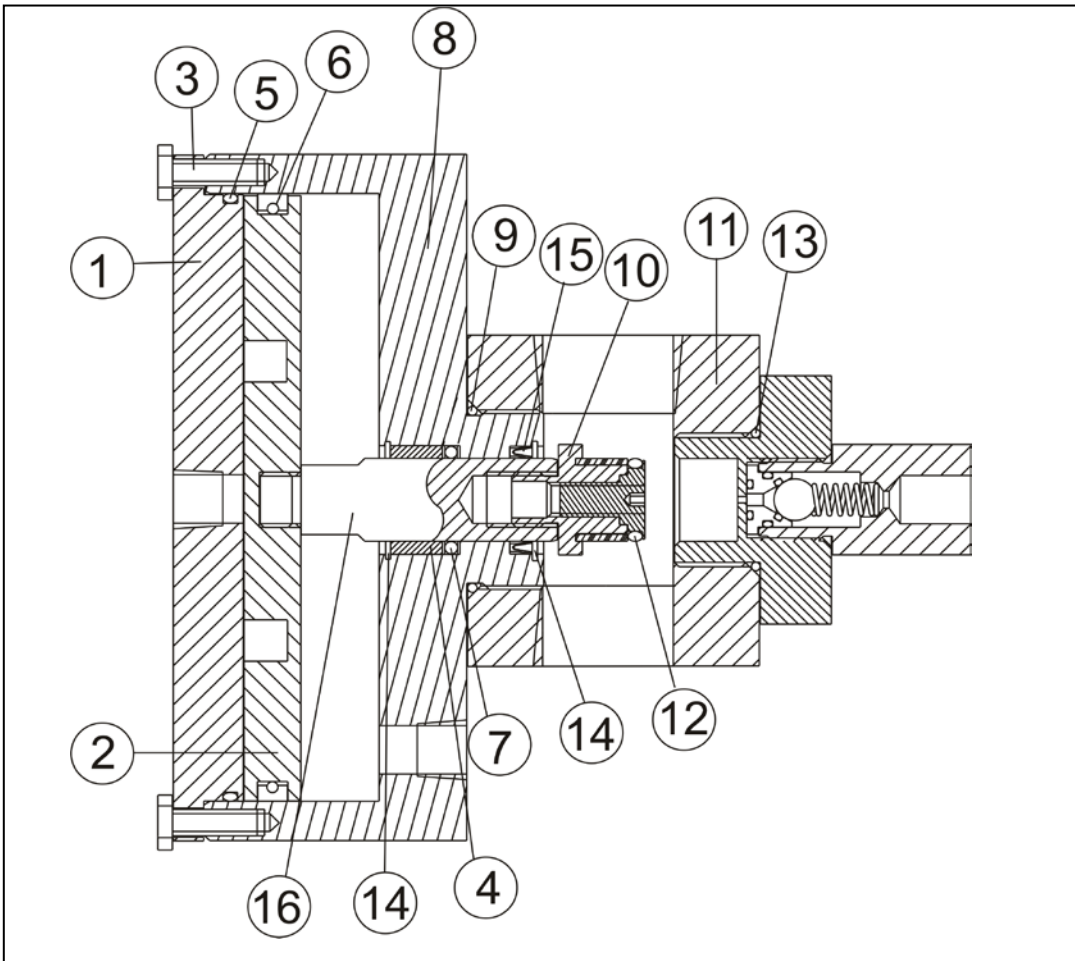

**FIGURE 4**

*Refer to this figure throughout the entire maintenance process.*

# MAINTENANCE

---

## 3.2 Instructions

- 3.2.1 Cut off the power from the timer/controller to the solenoid.
- 3.2.2 Close the valve between the instrument air and the sampler's motor.
- 3.2.3 Close the valve on the product inlet of the sample receiver.
- 3.2.4 Isolate the sampling system from the pipeline via the pipeline isolation valves.
- 3.2.5 Carefully depressurize and disconnect the instrument air from the system.
- 3.2.6 Carefully depressurize the rest of the sampling system from the pipeline.
- 3.2.7 Disconnect all of the inlet and outlet tubing from the sampler.
- 3.2.8 Unscrew the body (Part 11) from the sampler motor (Part 8).
- 3.2.9 Replace the seal (Part 9) on the motor body.

### **N** NOTE

New seals supplied in spare parts kits are not lubricated. They should be lightly coated with lubrication grease (Dow Corning 111 [DC 111] grease or equivalent lubricant) before they are installed into the equipment. This helps with the installation of the seals while reducing the risk of damage when positioning them on the parts. After the seals are installed, some additional lubrication can be applied to the shaft or cylinder inner diameters to allow a smooth transition of parts.

- 3.2.10 Unscrew the hex head machine screws (Part 3) and remove the motor top (Part 1).
- 3.2.11 Replace the seal (Part 5) in the motor top.
- 3.2.12 Remove the collection assembly (Part 10) from the shaft (Part 16).
- 3.2.13 Remove the motor piston (Part 1) from the shaft.
- 3.2.14 Examine the polished areas of the shaft for a smooth, clean finish. If scratches are present, the shaft will need replacement.
- 3.2.15 Replace the seal (Part 6) on the motor piston.
- 3.2.16 Remove both retaining rings (Part 14) from the motor.
- 3.2.17 Replace the variseal (Part 15) around the shaft.
- 3.2.18 If applicable, remove the packing nut in the body (*for APF model only*).
- 3.2.19 Replace the wiper in the packing nut (*for APF model only*).
- 3.2.20 Remove the bearing and replace the seal (Part 7).
- 3.2.21 Make sure that the bearing (Part 4) is not damaged. Replace if necessary.
- 3.2.22 Reinsert the bearing.
- 3.2.23 Reinstall both of the retaining rings.
- 3.2.24 Reinstall the packing nut (*for APF model only*).
- 3.2.25 Refer to Section 3.3 for collection head maintenance.

# MAINTENANCE

## 3.3 Collection head maintenance

### 3.3.1 Vanishing Chamber Collection Head Maintenance

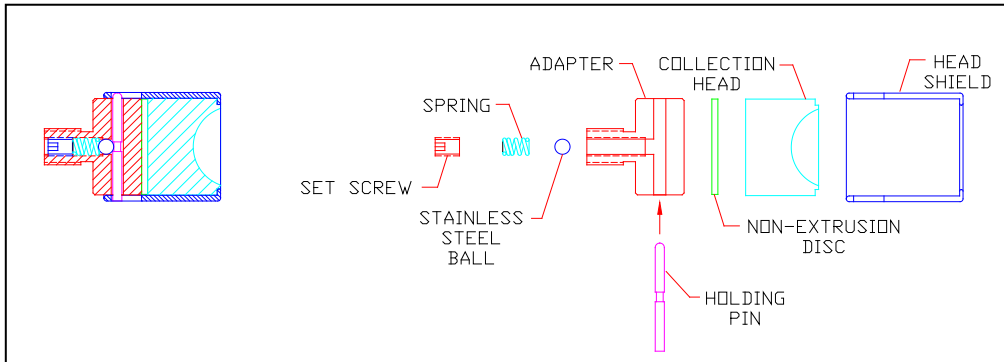

**Figure 5**

Refer to this figure for the following steps.

- Push the holding pin, and slide the shield off the adapter.
- Push the collection head and non-extrusion disc out of the shield.
- Lightly lubricate the inside of the shield and insert a new collection head and non-extrusion disc (unless the old disc is still in good condition).

#### **N** NOTE

All collection heads are marked on the back side with the size, compound, and durometer. Take note of what you are replacing. i.e. "V-70 1.0" or "V74" is a 70 durometer Viton collection head, 1.0 cc in volume. Consult Welker for other compounds available.

- Put the ball, spring and set screw back into the adapter.
- Place the adapter back onto the shaft.
- Put the shield back onto the adapter.
- Remove the vacuum breaker disc and the spider seal. Check both pieces for damage.
- Reinsert a new vacuum breaker disc and spider seal if the old ones are damaged.

### 3.3.2 B-Style Collection Head Maintenance

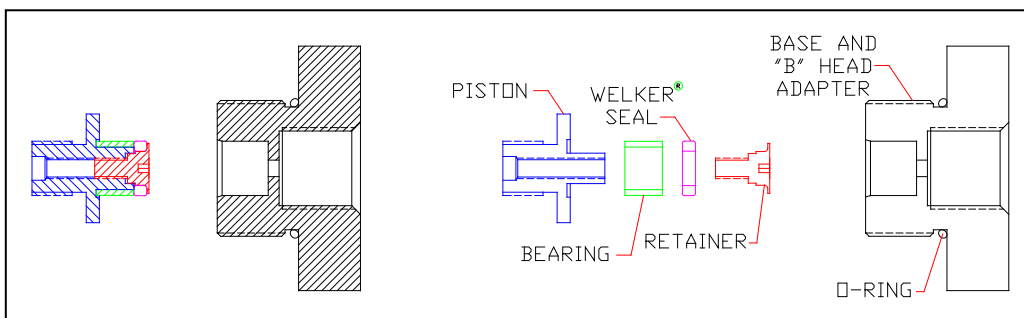

**Figure 6**

Refer to this figure for the following steps.

# MAINTENANCE

- a) Replace the seal on the collection head piston.
- b) Check the bearing on the collection head for damage and replace it if necessary.
- c) Unscrew the base from the body of the sampler.
- d) Examine the cylinder finish, and replace if it is damaged.
- e) Replace the seal on the base, and reinstall the base to the body of the sampler.

### 3.3.3 L-Style Collection Head

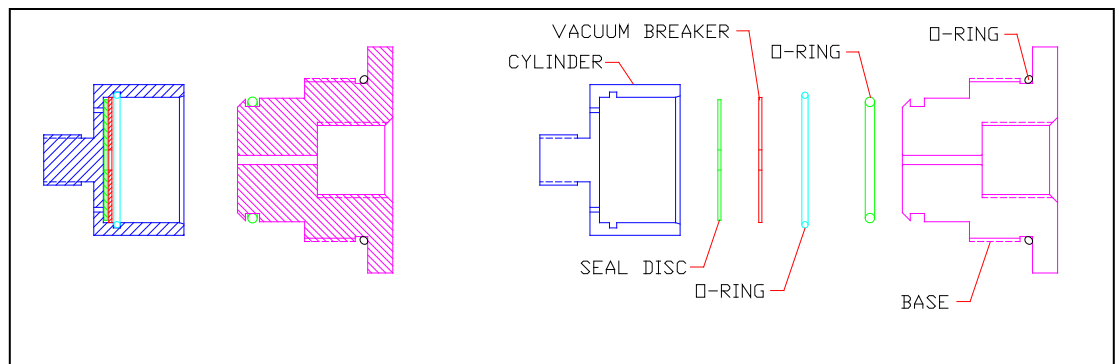

**Figure 7**

Refer to this figure for the following steps.

- a) Replace the seal inside the collection cylinder.
- b) Unscrew the base from the body of the sampler.
- c) Replace both seals on the base, and re-install the base to the body of the sampler.

### 3.4 Relief maintenance

- 3.4.1 Close pipeline isolation valve and relieve pressure from sampler.
- 3.4.2 Disconnect tubing and remove relief cap by unscrewing counterclock wise.

#### 3.4.3 For an Inline Relief

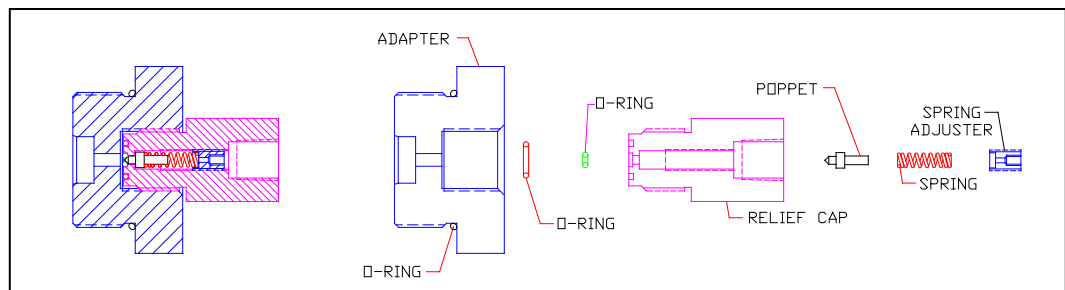

**Figure 8**

Refer to this figure for the following steps.

- a) Disconnect tubing and remove the inline relief cap.
- b) Replace the two seals on the face.
- c) Remove the spring adjustment screw, spring, and poppet. Examine the poppet sealing surface for damage. Replace, if necessary.

# MAINTENANCE

- d) Reassemble the pieces and replace the relief cap into the body, making sure the face seals are in proper alignment to ports.
- e) Reinstall the sample out tubing.
- f) Relief is now ready to be reset.

## 3.4.4 For a B Relief

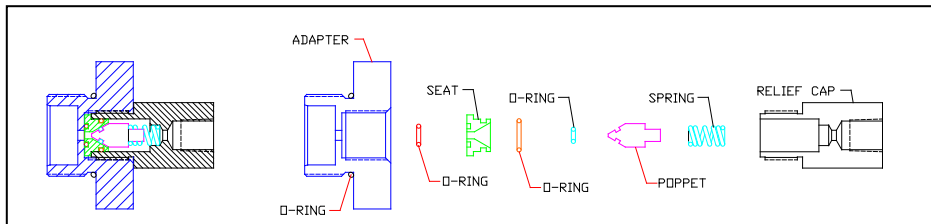
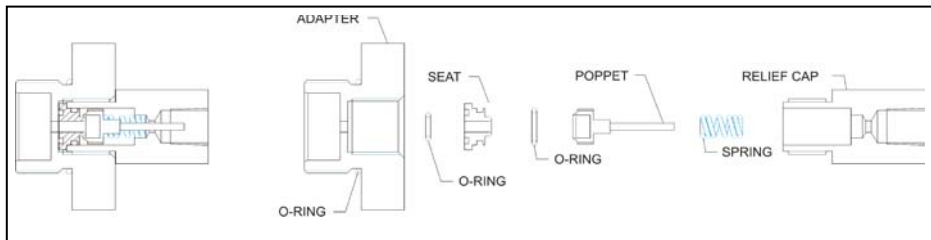

**Figure 9**

Refer to this figure for the following steps.

- a) Remove the relief cap from the base and slide the relief out of the base.
- b) Inspect the poppet and seat for wear. The seat should have a smooth tapered finish.
- c) Replace the seals on the poppet and seat.
- d) Replace the seal on the relief cap.
- e) Reinstall the relief assembly into the relief cap and the relief cap into the base.

## 3.4.5 For a Sand Relief

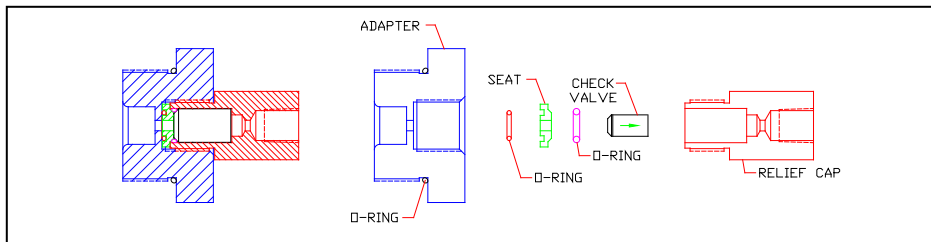

**Figure 10**

Refer to this figure for the following steps.

- a) Remove the relief cap from the adapter and slide the seat out of the adapter.
- b) Replace the seals on the seat and inspect the poppet seal. This seal, under normal operation, will show a smooth indentation from the seat. Replacement will be necessary if the wear pattern is greater or the seal has deteriorated.
- c) Reinstall the relief assembly into the relief cap and the relief cap into the adapter.

## 3.4.6 For a Cartridge Relief



**Figure 11**

Refer to this figure for the following steps.

# MAINTENANCE

---

- a) Maintenance for the relief will be simply to replace the cartridge and the cartridge seat.

**N** NOTE

When replacing the relief with a new cartridge, install it with the arrow in the direction of the flow of the sample.

## 3.5 Reassembly

- 3.5.1 Reinstall the collection assembly (Part 10) to the shaft (Part 16).
- 3.5.2 Reinstall the bearing (Part 4) to the shaft.
- 3.5.3 Reinsert the shaft into the body (Part 11).
- 3.5.4 Reattach the motor (Part 8) onto the body.
- 3.5.5 Reattach the motor piston (Part 2).
- 3.5.6 Reattach the motor top (Part 1).
- 3.5.7 Reinsert the hex screws (Part 3).

**!** CAUTION

O-ring seals can be cut or destroyed during assembly. Please use care when assembling the sampler.

- 3.5.8 Repeat Sections 2.1-2.3 for reinstallation.



13839 West Bellfort, Sugar Land, Texas 77498-1671

Phone: (281) 491-2331

Fax: (281) 491-8344

Toll Free: (800) 776-7267

Web Page: [www.welkereng.com](http://www.welkereng.com)