



Welker[®] Crude Oil Sample Container

The Welker Crude Oil Sample Container is available in all sizes. The container incorporates all features desired on crude oil sample receptacles and meets API Chapter 8, Section 2, ISO 3171 and ASTM D4177 design requirements.

Features

- Epoxy coating
- Full-length sight glass
- Explosion-proof pump
- Downcomer to mix, circulate, and sweep the bottom of the container
- Gauge, relief, and vacuum breaker
- Quick-open top (for easy cleaning)
- Static mixer
- Closure with outside slope to ensure moisture seal

Shown: 5-gallon size

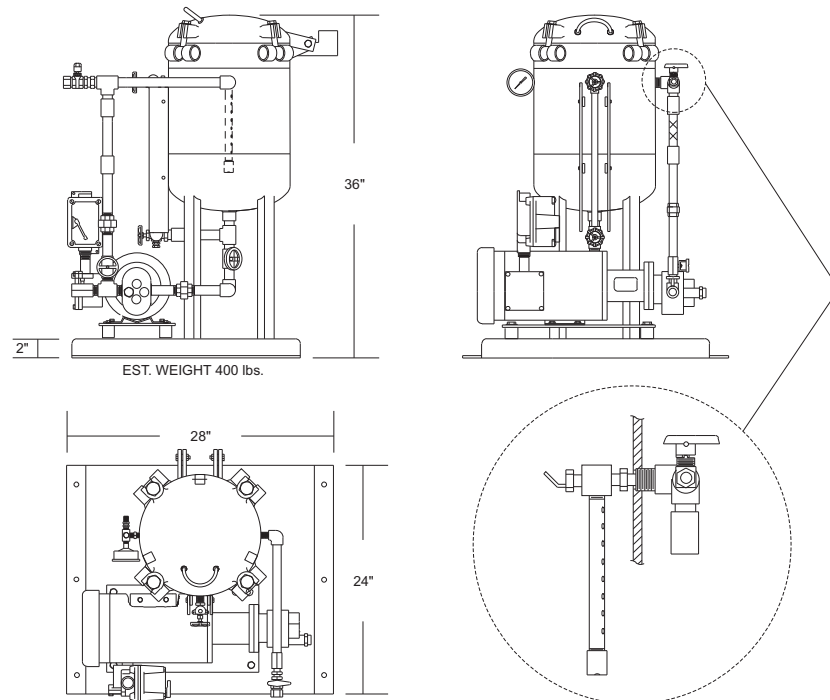

Welker[®] ... When Excellence Counts!

Welker® Crude Oil Sample Container

General Description

Major oil companies and petroleum cargo inspection agencies worldwide rely on the Welker Crude Oil Sampler for pinpoint accuracy and reliability.

The Welker Crude Oil Sampler extracts a representative sample from a properly conditioned line and pumps it into a sample container.

Welker Crude Oil Sample receivers are designed to preserve the integrity of the sample during the entire sampling process and provide proper mixing of the collected sample so the laboratory sub-sample is truly representative of the entire delivery or batch of product.

Components

Various samplers, controllers, containers, mixing skids and sample conditioners.

Features & Benefits

Sample Containers

- Choose from heated, atmospheric or piston-style
- Transportable stainless steel or stationary with baked-on epoxy coating for greater accuracy
- Three mixing devices – gear pump, static and 3-process mixing
- Provides good vortex and full swirling action for proper conditioning.

Specifications*

Sample Container

- Atmospheric container (not constant pressure) for stabilized crude — Stationary skid-mounted (SCC): 3 gallon to 30 gallon (11 L to 110 L)
- Full-length downcomer
- Full open lid
- 5-horsepower motor
- Mixing loop with Komax® mixer

Options

- Sight glass
- High-level shut-off
- Heat trace
- Enclosure
- Liquid level
- Multiple draw-off
- Insulation
- PLC control packages

Accessories

- High-level indicator
- Proprietary electronic logic control system

Manufactured under U.S. Patent:

5,213,586

*Specifications subject to change without notice.
Drawings/Photos may be shown with optional equipment.



13839 West Bellfort • Sugar Land, TX 77498-1671
Telephone: (281) 491-2331 • Toll Free: (800) 776-7267 • Fax: (281) 491-8344
Sales Email: Sales@welkereng.com • Web Site: www.welkereng.com