

WELKER[®]
ENGINEERING COMPANY

ISO-9001
CERTIFIED
SINCE 1992

Welker Constant Pressure Sample Cylinder

Style CP-42GA

The Welker CP-42GA constant pressure sample cylinder has been designed to hold a representative sample at the same condition as in the pipeline. An inert precharge gas holds the piston against the product at slightly above pipeline pressure, thus preventing a phase change to occur. All 7075-T6 aluminum construction allows for high strength as well as light weight.

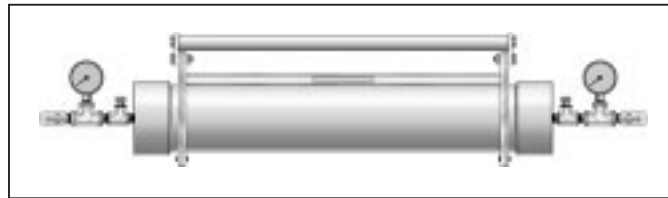

Features

- Holds representative sample at pipeline conditions.
- Equipped with external volume tracker for exact volume indication.
- Constructed of 7075-T6 aluminum.
- Standard working pressure of 1800 psi (124 Bar).
- Screwed or NPT connections.
- Safety burst discs.
- Pressure indication gauges.
- Inlet and precharge valve.
- Carrying handle.
- Magnetic volume indicator.

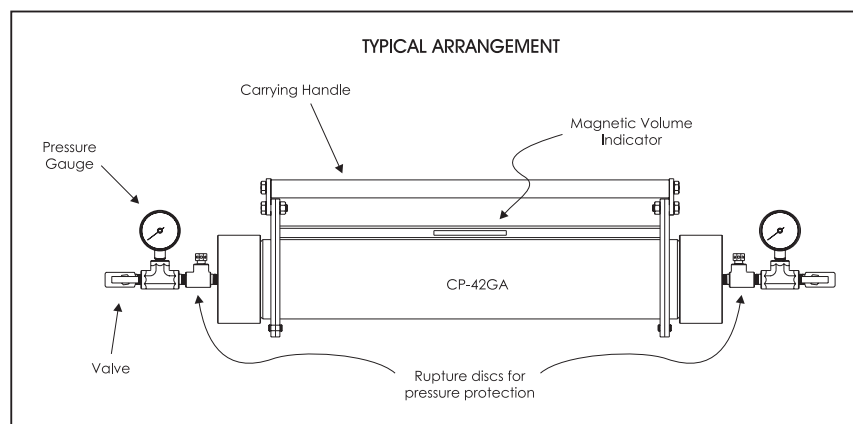

Welker... When Excellence Counts!

Welker Constant Pressure Sample Cylinder

Specifications

- **Application**

The CP-42GA can be used with all products that are compatible with the materials of construction and seal material.

- **Pressure Rating**

Standard working pressure up to 1800 psi (124 Bar).

- **Temperature Rating**

From -20 to +250 °F (-29 to +121 °C)

- **Sample Container Sizes**

4000 cc standard.

- **Materials**

Standard material used is 7075-T6 aluminum with Viton® and Fluorotrel® seals.

- **Connections**

Product and precharge ports are 1/4" FNPT .

- **Required Utilities**

A nitrogen bottle could be utilized for precharge gas blanket. Other gases typically used are helium and argon. CAUTION: Never use liquids for precharge pressure.

- **Weight**

4000 cc - 7 lbs (3.2 kg)

- **Non-standard designs available upon request**

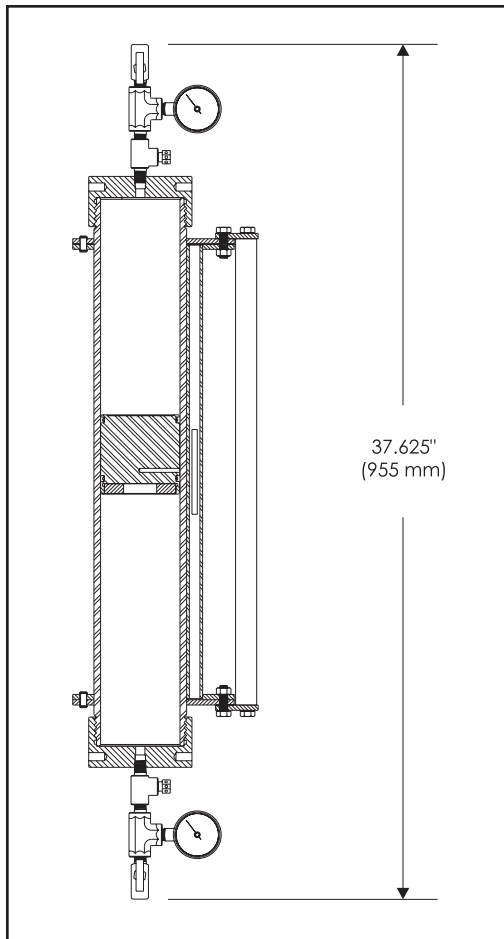

Options Available

- Other volumes
- Other materials of construction
- Gravity mixer
- 1/2" FNPT porting
- Resettable spring reliefs
- Certificates (material 3.1 lb, hydrostatic, functional, conformity, etc.)

Other Welker Products

- In-line Samplers
- Pipeline Equipment Insertion Devices
- Cylinder Carrying Cases
- Sample Take-Off Probes
- Probe Regulators
- Control Valves

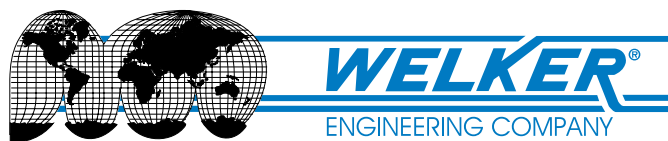

P.O. Box 138 • Sugar Land, TX 77487-0138
Phone: 281-491-2331 • Domestic Fax: 281-491-8344 • International Fax: 281-242-5623
Email: prosamp@welkereng.com • Web Site: www.welkereng.com

1-800-PRO-SAMP