



Welker[®] Instrument Supply Dehydration Assembly

Style DA-1

General Description

This ideal protection for pneumatic controllers is another Welker original product design. The DA-1 incorporates two F-5 style filter dryers (mounted in parallel) with high-pressure instrument regulators mounted in the outlet of each filter and connected into a common output line. One regulator should be set 20 psi higher than the other so that only the filter dryer on this regulator is in service. Should the charge become saturated and the regulator freeze off due to hydrates, then the output will drop to the setting of the second regulator without interrupting service. A pressure gauge in the output line would make this condition immediately noticeable so that a new charge could be installed in the primary filter dryer without interrupting service.

Welker Keeps You Operational!

Features

- Replacement filter cartridges
- 4-micron filtration
- Silica gel/charcoal media (standard)
- Other filter media available for special conditions
- 1/4" NPT connections
- Individual cartridge replacement without shutdown of supply

Welker[®] ... Global Solutions for Your Needs!

Welker® Instrument Air Dehydration Assembly

Specifications*

Application

The DA-1 can be used with all products that are compatible with the materials of construction and seal material

Pressure Range

Maximum pressure range is 1,480 psi (102 Bar)
— 600 ANSI

Temperature Rating

Up to +200°F (+94°C)

Flow Rates

50 scfm

Materials

Standard material used on body and valves is carbon steel, stainless steel for fittings, brass regulators and Nitrile seals.

Connections

1/4" NPT connections

Non-standard design available upon request.

*Specifications subject to change without notice.
Drawings/Photos may be shown with optional equipment.

Options Available

- Stainless steel or aluminum regulators
- Higher pressure ranges
- Various filtration mediums
- 1/2" NPT connections
- Sight glass indicator for visual saturation confirmation

Other Welker Products

- Welker Jet® control valves
- Instrumentation protection
- Automatic pipeline insertion devices
- Gas sampling systems
- Chemical injection systems

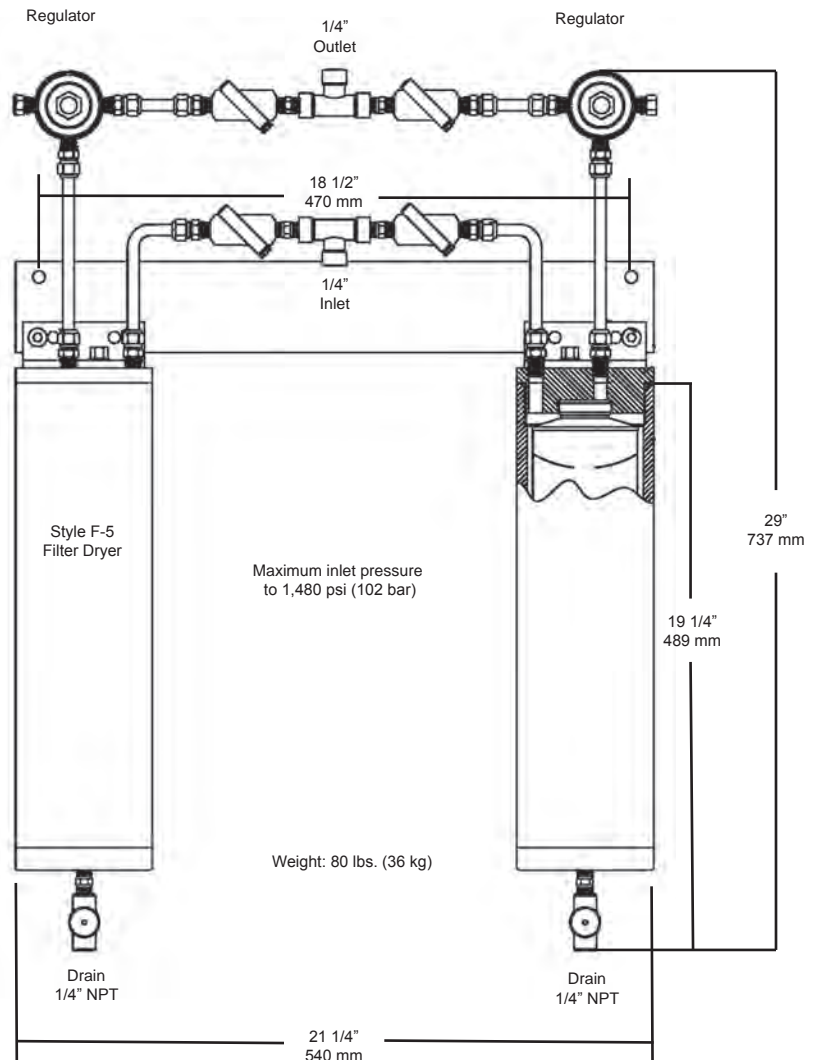

13839 West Bellfort • Sugar Land, TX 77498-1671
Telephone: (281) 491-2331 • Toll Free: (800) 776-7267 • Fax: (281) 491-8344
Sales Email: Sales@welkereng.com • Web Site: www.welkereng.com