



# Welker<sup>®</sup> Composite Gas Sampler

*Vanishing Chamber<sup>™</sup> style*

The heart of the Welker<sup>®</sup> Gas Sampling System is the GSS-4 Vanishing Chamber<sup>™</sup> pump. With its unique collection head design, the GSS-4 is the best sampler pump available.

With each actuation of the sampler, the collection head is compressed. This causes the chamber in the collection head to vanish, thereby totally voiding itself of product. Complete voiding of the collection chamber is an important part of collecting a representative sample. It ensures that each new “bite” will be representative of what is flowing through the line at that instant.

**Welker Makes It Better!**

## Features

- Stainless steel construction
- All wetted parts are stainless steel
- Easy routine maintenance
- New shallow collection head design
- Easy-to-adjust inline relief
- Minimum number of moving parts
- No filters or regulators in sampler path
- Compact dimensions
- Integrated sampler manifold
- Purges complete sample collection area

Manufactured under U.S. Patents:

5,996,425  
5,945,611  
5,531,130  
5,406,855  
5,303,599

Specifications subject to change without notice.  
Drawings/Photos may be shown with optional equipment.

Welker<sup>®</sup> ... Engineering World Class Solutions!

# Welker® Composite Gas Sampler

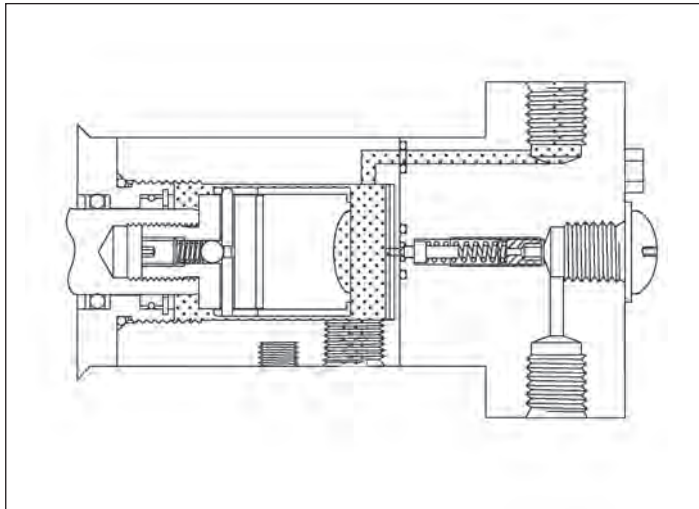

## OPEN

*Product fills the chamber in the collection head.*

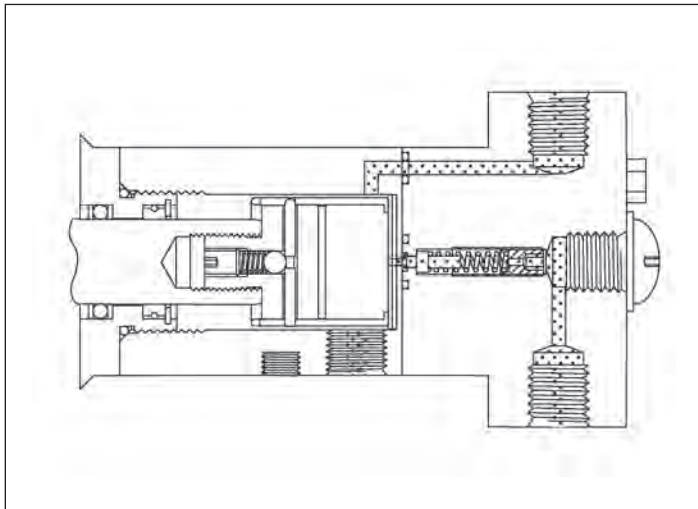

## VOIDED

*The collection head is pressed against the opposing flat surface. The chamber in the collection head vanishes, "pumping" product past the inline relief and into the sample cylinder. The inline relief isolates the collected sample from the pipeline.*

## Applications

The GSS-4 Vanishing Chamber™ Sampler features Welker's unique collection head. Its design allows Welker gas samplers to PUMP the product into the collection cylinder, regardless of pipeline pressure.

Because sampling conditions vary from one application to another, Welker offers two styles of inline reliefs for the GSS-4.

**EXTERNALLY ADJUSTABLE INLINE RELIEF** serves the same purpose as the standard inline relief, but may be adjusted if needed while the sampler is in operation.

**BALANCED INLINE RELIEF** for sampling from pipelines with widely varying pressures. This relief is tied directly to pipeline pressure and automatically compensates for variations.

The GSS-4 Vanishing Chamber™ Sampler sets new standards in versatility and accuracy.

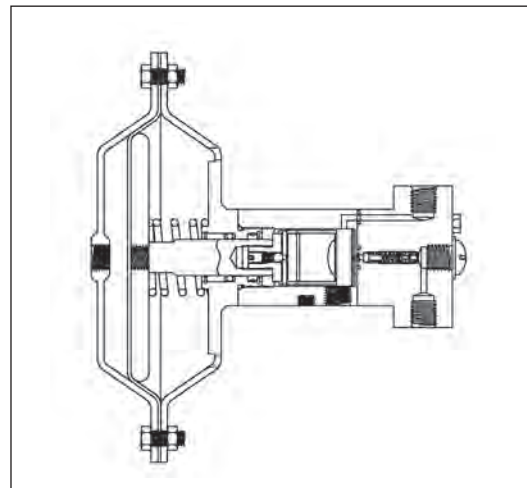

Specifications subject to change without notice.  
Drawings/Photos may be shown with optional equipment.

Welker samplers perform accurately!



13839 West Belfort • Sugar Land, TX 77498-1671  
Telephone: (281) 491-2331 • Toll Free: (800) 776-7267 • Fax: (281) 491-8344  
Sales Email: Sales@welkereng.com • Web Site: www.welkereng.com